



GL50N03A4

GL Silicon N-Channel Power MOSFET

General Description

The GL50N03A4 uses advanced trench technology and design to provide excellent $R_{DS(ON)}$ with low gate charge. It can be used in a wide variety of applications. The package form is TO-252, which accords with the RoHS standard.

V_{DSS}	30	V
I_D	50	A
P_D	60	W
$R_{DS(ON)type}$	5.8	m Ω

Features

- $R_{DS(ON)} < 7.2m\Omega @ V_{GS}=10V$ (Typ5.8m Ω)
- High density cell design for ultra low R_{dson}
- Fully characterized avalanche voltage and current
- Excellent package for good heat dissipation

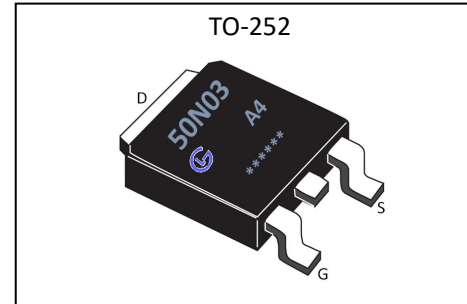

Applications

- Power switching application
- Hard switched and high frequency circuits
- Uninterruptible power supply

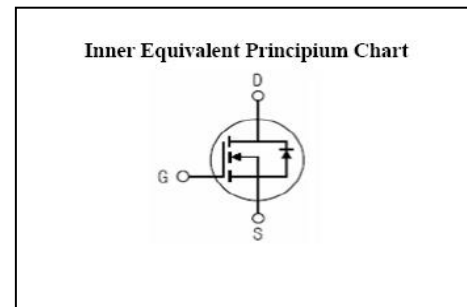

Absolute (Tc= 25°C unless otherwise specified)

Symbol	Parameter	Rating	Units
V_{DSS}	Drain-to-Source Voltage	30	V
I_D	Continuous Drain Current	50	A
I_{DM}	Pulsed Drain Current	200	A
V_{GS}	Gate-to-Source Voltage	± 20	V
P_D	Power Dissipation	60	W
E_{AS}	Single pulse avalanche energy ^{a5}	70	mJ
T_J, T_{stg}	Operating Junction and Storage Temperature Range	175, -55 to 175	°C

Caution Stresses greater than those in the "Absolute Maximum Ratings" may cause permanent damage to the device

Thermal Characteristics

Symbol	Parameter	Typ.	Units
$R_{\theta JC}$	Junction-to-Case ^{a2}	2.5	°C/W



GL50N03A4

GL Silicon N-Channel Power MOSFET

Electrical Characteristics (Tc= 25°C unless otherwise specified)

OFF Characteristics						
Symbol	Parameter	Test Conditions	Rating			Units
			Min.	Typ.	Max.	
V _{DSS}	Drain to Source Breakdown Voltage	V _{GS} =0V, I _D =250μA	30	--	--	V
I _{DSS}	Drain to Source Leakage Current	V _{DS} =30V, V _{GS} =0V, T _a =25°C	--	--	1.0	μA
I _{GSS(F)}	Gate to Source Forward Leakage	V _{GS} =+20V	--	--	0.1	μA
I _{GSS(R)}	Gate to Source Reverse Leakage	V _{GS} =-20V	--	--	-0.1	μA

ON Characteristics ^{a3}						
Symbol	Parameter	Test Conditions	Rating			Units
			Min.	Typ.	Max.	
R _{DS(ON)}	Drain-to-Source On-Resistance	V _{GS} =10V, I _D =25A	--	5.8	7.2	mΩ
R _{DS(ON)}	Drain-to-Source On-Resistance	V _{GS} =4.5V, I _D =25A	--	9	12	mΩ
V _{GS(TH)}	Gate Threshold Voltage	V _{DS} =V _{GS} , I _D =250μA	1.0	1.4	3.0	V

Pulse width tp ≤ 380μs, δ ≤ 2%

Dynamic Characteristics ^{a4}						
Symbol	Parameter	Test Conditions	Rating			Units
			Min.	Typ.	Max.	
g _{fs}	Forward Transconductance	V _{DS} =5V, I _D =25A	15	--	--	S
C _{iss}	Input Capacitance	V _{GS} =0V, V _{DS} =15V f=1.0MHz	--	1800	--	pF
C _{oss}	Output Capacitance		--	240	--	
C _{rss}	Reverse Transfer Capacitance		--	180	--	

Resistive Switching Characteristics ^{a4}						
Symbol	Parameter	Test Conditions	Rating			Units
			Min.	Typ.	Max.	
t _{d(ON)}	Turn-on Delay Time	V _{DD} =10V, I _D =25A V _{GS} =10V, R _G =1.8Ω	--	10	--	ns
t _r	Rise Time		--	9	--	
t _{d(OFF)}	Turn-Off Delay Time		--	30	--	
t _f	Fall Time		--	6	--	
Q _g	Total Gate Charge	V _{DD} =10V, I _D =25A V _{GS} =10V	--	23	--	nC
Q _{gs}	Gate to Source Charge		--	8	--	
Q _{gd}	Gate to Drain ("Miller") Charge		--	4.5	--	



GL50N03A4

GL Silicon N-Channel Power MOSFET

Source-Drain Diode Characteristics

Symbol	Parameter	Test Conditions	Rating			Units
			Min.	Typ.	Max.	
I_S	Continuous Source Current ^{a2} (Body Diode)		--	--	50	A
V_{SD}	Diode Forward Voltage ^{a3}	$I_S=50A, V_{GS}=0V$	--	--	1.2	V

^{a1}: Repetitive Rating: Pulse width limited by maximum junction temperature.

^{a2}: Surface Mounted on FR4 Board, $t \leq 10\text{sec}$.

^{a3}: Pulse Test: Pulse Width $\leq 300\mu\text{s}$, Duty Cycle $\leq 2\%$.

^{a4}: Guaranteed by design, not subject to production

^{a5}: EAS condition: $T_j=25^\circ\text{C}, V_{DD}=15V, V_{GS}=10V, L=1.0\text{mH}, R_g=25\Omega$

Test Circuits

1) E_{AS} test Circuits

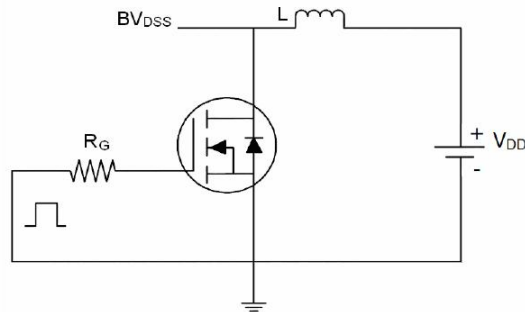

2) Gate charge test Circuit:

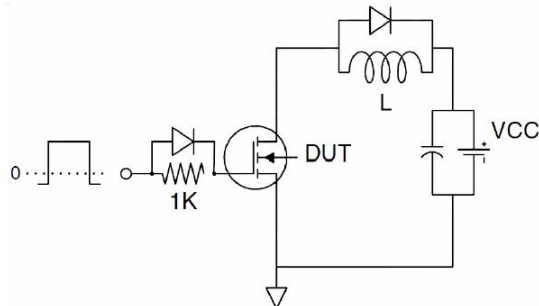

3) Switch Time Test Circuit:

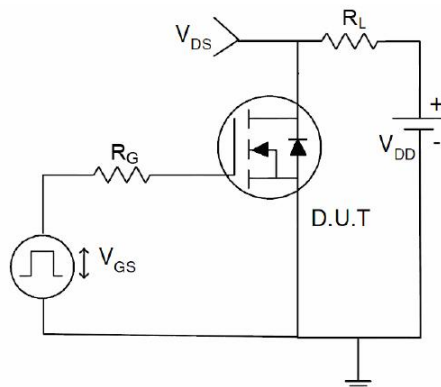



GL50N03A4

GL Silicon N-Channel Power MOSFET

Characteristics Curves

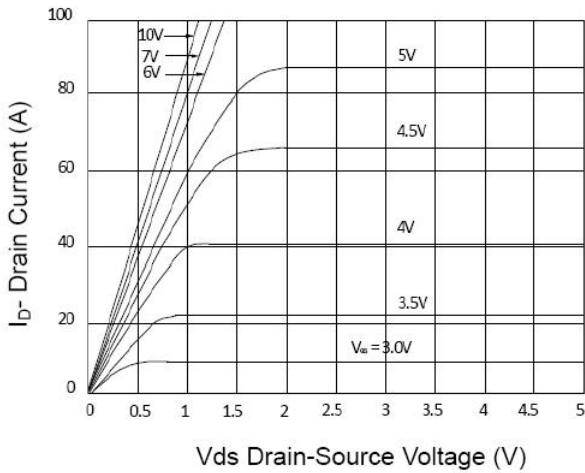

Figure 1 Output Characteristics

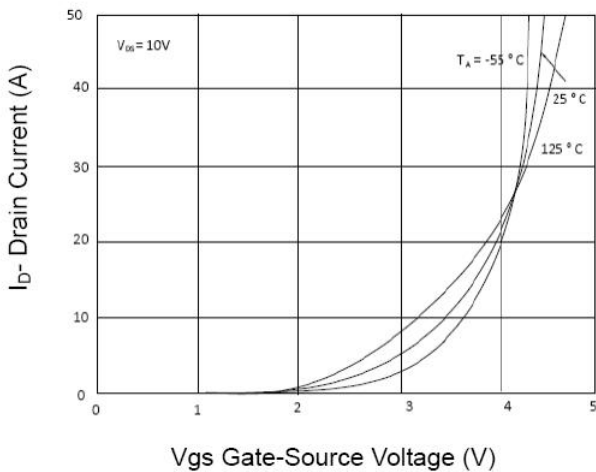

Figure 2 Transfer Characteristics

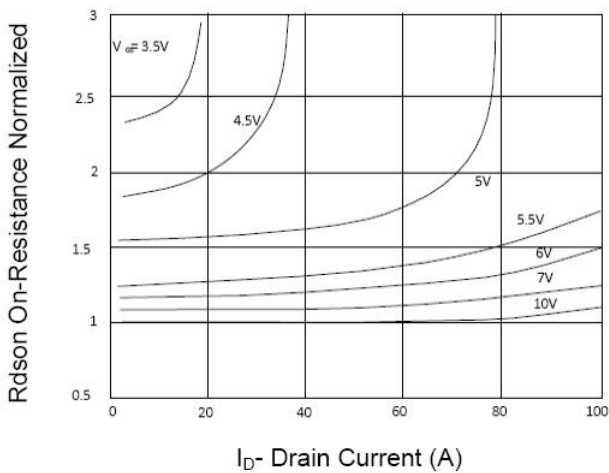

Figure 3 Rdson- Drain Current

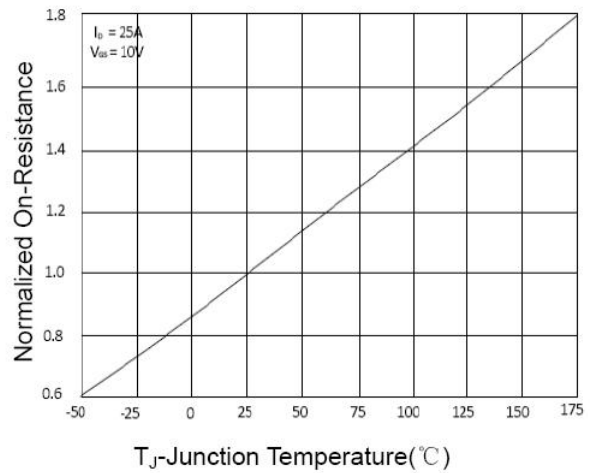

Figure 4 Rdson-Junction Temperature

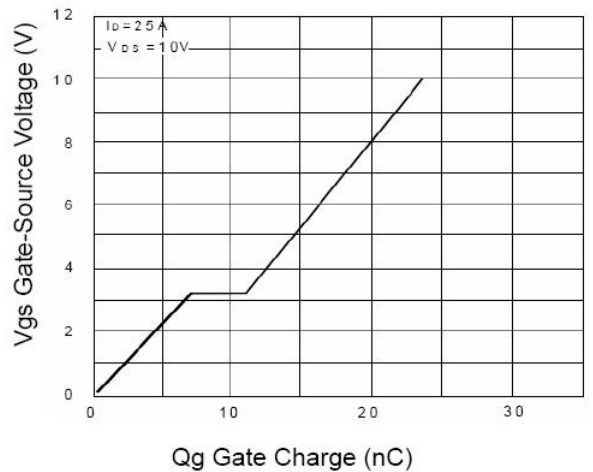

Figure 5 Gate Charge

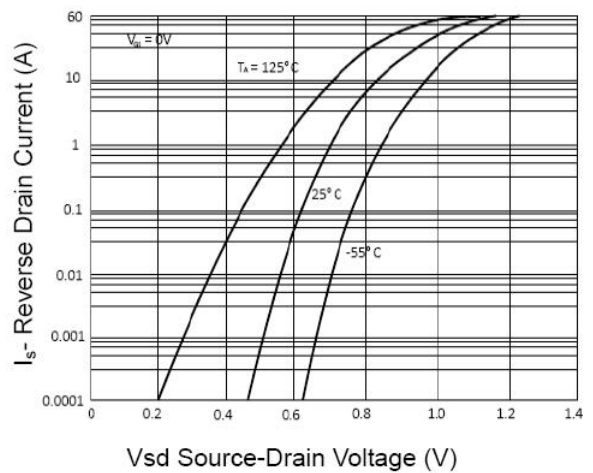

Figure 6 Source- Drain Diode Forward



GL50N03A4

GL Silicon N-Channel Power MOSFET

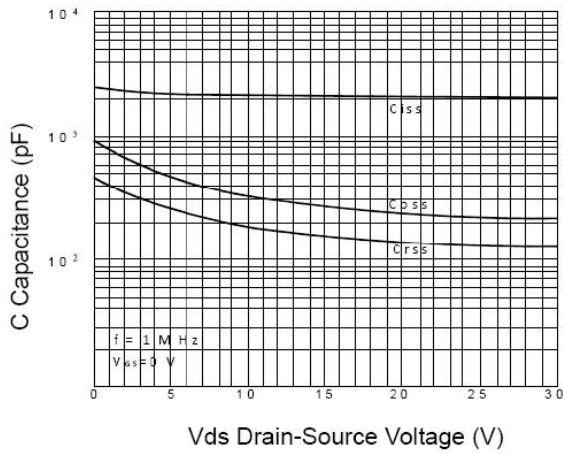

Figure 7 Capacitance vs Vds

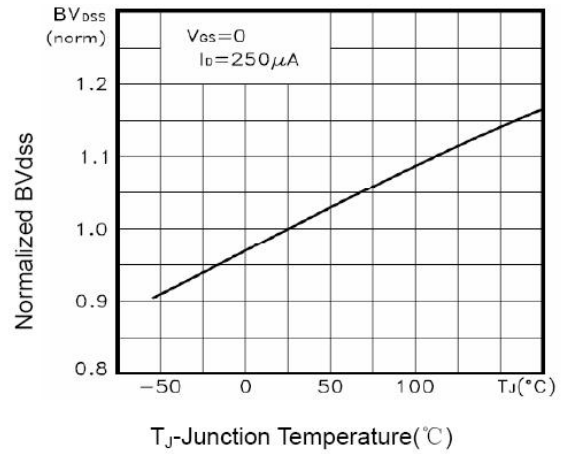

Figure 9 BV_{DSS} vs Junction Temperature

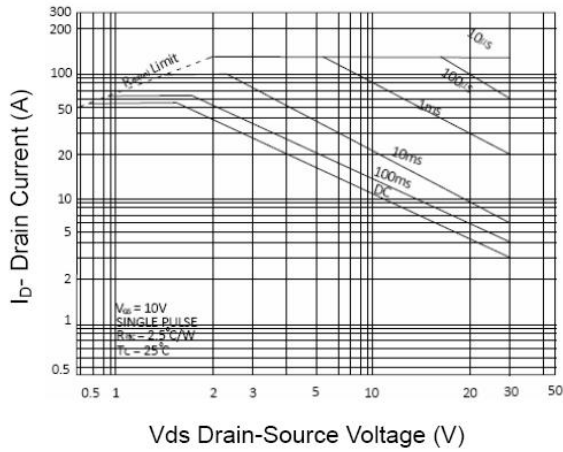

Figure 8 Safe Operation Area

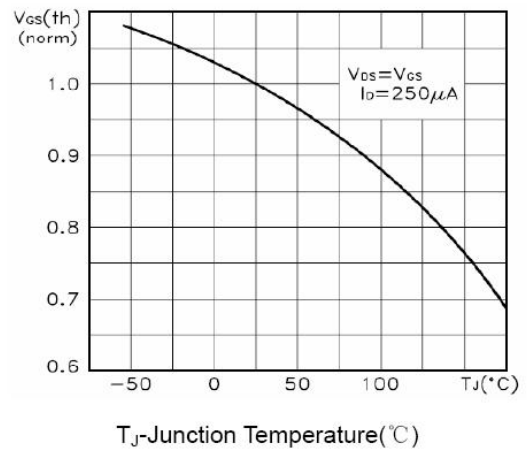

Figure 10 $V_{GS(th)}$ vs Junction Temperature

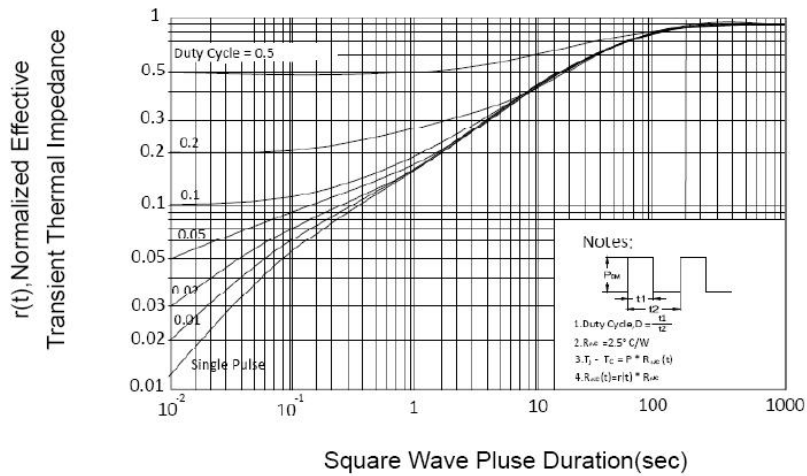

Figure 11 Normalized Maximum Transient Thermal Impedance