



GL80N06ADD

GL Silicon N-Channel Power MOSFET

General Description:

The GL80N06ADD uses advanced trench technology and design to provide excellent $R_{DS(ON)}$ with low gate charge. It can be used in a wide variety of applications. The package form is PDFN 5×6, which accords with the RoHS standard.

V_{DSS}	60	V
I_D	80	A
P_D	85	W
$R_{DS(ON)type}$	5.5	m Ω

Features:

- $R_{DS(ON)} < 6m\Omega @ V_{GS}=10V$ (Typ5.5m Ω)
- High density cell design for ultra low R_{dson}
- Fully characterized avalanche voltage and current
- Excellent package for good heat dissipation

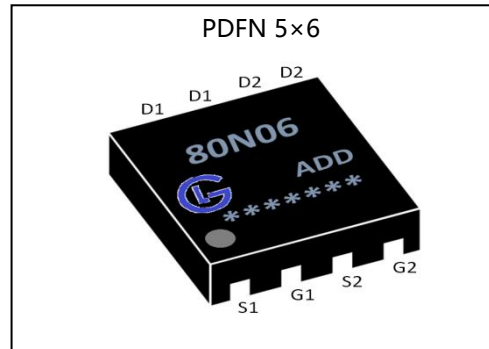

Applications:

- Power switching application
- Hard switched and high frequency circuits
- Uninterruptible power supply

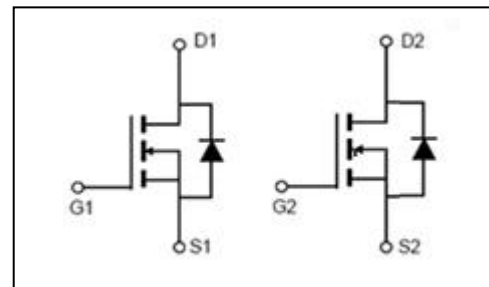

Absolute (Tc= 25°C unless otherwise specified):

Symbol	Parameter	Rating	Units
V_{DSS}	Drain-to-Source Voltage	60	V
I_D	Continuous Drain Current	80	A
I_{DM}	Pulsed Drain Current	320	A
V_{GS}	Gate-to-Source Voltage	± 20	V
P_D	Power Dissipation	85	W
E_{AS}	Single pulse avalanche energy ^{a5}	400	mJ
T_J, T_{stg}	Operating Junction and Storage Temperature Range	150, -55 to 150	°C



GL80N06ADD

GL Silicon N-Channel Power MOSFET

Electrical Characteristics ($T_c = 25^\circ\text{C}$ unless otherwise specified) :

OFF Characteristics						
Symbol	Parameter	Test Conditions	Rating			Units
			Min.	Typ.	Max.	
V_{DSS}	Drain to Source Breakdown Voltage	$V_{GS}=0V, I_D=250\mu A$	60	--	--	V
I_{DSS}	Drain to Source Leakage Current	$V_{DS}=60V, V_{GS}=0V, T_a=25^\circ\text{C}$	--	--	1.0	μA
$I_{GSS(F)}$	Gate to Source Forward Leakage	$V_{GS}=+20V$	--	--	0.1	μA
$I_{GSS(R)}$	Gate to Source Reverse Leakage	$V_{GS}=-20V$	--	--	-0.1	μA

ON Characteristics ^{a3}						
Symbol	Parameter	Test Conditions	Rating			Units
			Min.	Typ.	Max.	
$R_{DS(ON)}$	Drain-to-Source On-Resistance	$V_{GS}=10V, I_D=40A$	--	5.5	6.0	m Ω
$V_{GS(TH)}$	Gate Threshold Voltage	$V_{DS}=V_{GS}, I_D=250\mu A$	1.0	--	2.5	V

Pulse width $t_p \leq 380\mu s, \delta \leq 2\%$

Dynamic Characteristics ^{a4}						
Symbol	Parameter	Test Conditions	Rating			Units
			Min.	Typ.	Max.	
g_{fs}	Forward Transconductance	$V_{DS}=10V, I_D=40A$	40	--	--	S
C_{iss}	Input Capacitance	$V_{GS}=0V, V_{DS}=30V$ $f=1.0\text{MHz}$	--	1700	--	pF
C_{oss}	Output Capacitance		--	360	--	
C_{rss}	Reverse Transfer Capacitance		--	5	--	

Resistive Switching Characteristics ^{a4}						
Symbol	Parameter	Test Conditions	Rating			Units
			Min.	Typ.	Max.	
$t_{d(ON)}$	Turn-on Delay Time	$V_{DD}=30V, I_D=40A$ $V_{GS}=10V, R_G=4.7\Omega$	--	6	--	ns
t_r	Rise Time		--	7	--	
$t_{d(OFF)}$	Turn-Off Delay Time		--	35	--	
t_f	Fall Time		--	8	--	
Q_g	Total Gate Charge	$V_{DD}=30V, I_D=40A$ $V_{GS}=10V$	--	30	--	nC
Q_{gs}	Gate to Source Charge		--	6	--	
Q_{gd}	Gate to Drain ("Miller")Charge		--	4	--	



GL80N06ADD

GL Silicon N-Channel Power MOSFET

Source-Drain Diode Characteristics						
Symbol	Parameter	Test Conditions	Rating			Units
			Min.	Typ.	Max.	
I_S	Continuous Source Current ^{a2} (Body Diode)		--	--	80	A
V_{SD}	Diode Forward Voltage ^{a3}	$I_S=80A, V_{GS}=0V$	--	--	1.2	V

Symbol	Parameter	Typ.	Units
$R_{\theta JC}$	Junction-to-Case ^{a2}	1.47	°C/W

^{a1}: Repetitive Rating: Pulse width limited by maximum junction temperature.

^{a2}: Surface Mounted on FR4 Board, $t \leq 10\text{sec}$.

^{a3}: Pulse Test: Pulse Width $\leq 300\mu\text{s}$, Duty Cycle $\leq 2\%$.

^{a4}: Guaranteed by design, not subject to production

^{a5}: EAS condition: $T_j=25^\circ\text{C}, V_{DD}=350\text{V}, V_G=10\text{V}, L=0.5\text{mH}, R_g=25\Omega$

Test circuit

1) EAS test Circuit

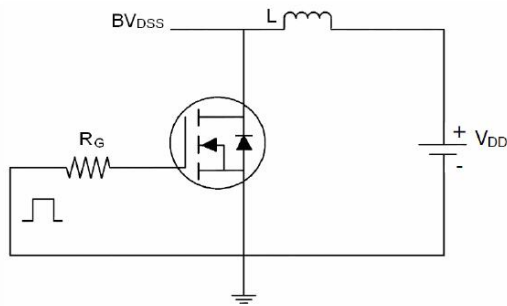

2) Gate charge test Circuit

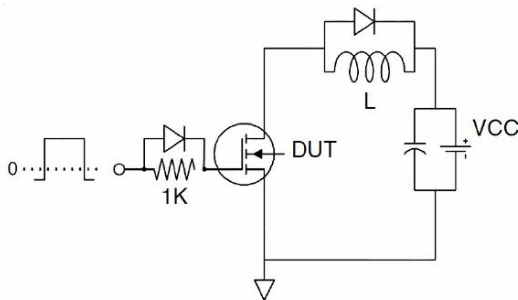

3) Switch Time Test Circuit

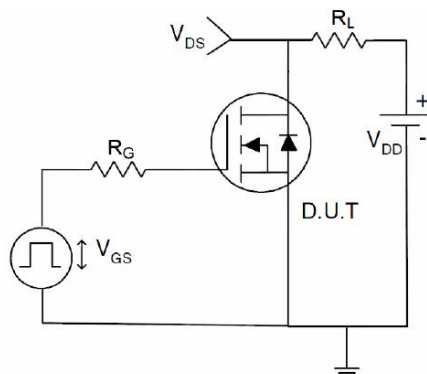



GL80N06ADD

GL Silicon N-Channel Power MOSFET

Typical Electrical and Thermal Characteristics

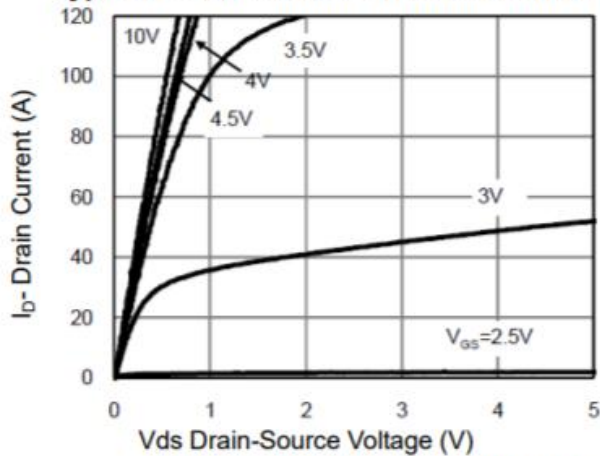

Figure 1 Output Characteristics

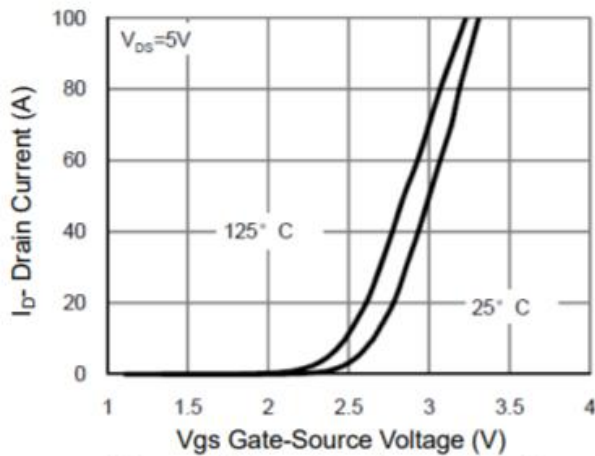

Figure 2 Transfer Characteristics

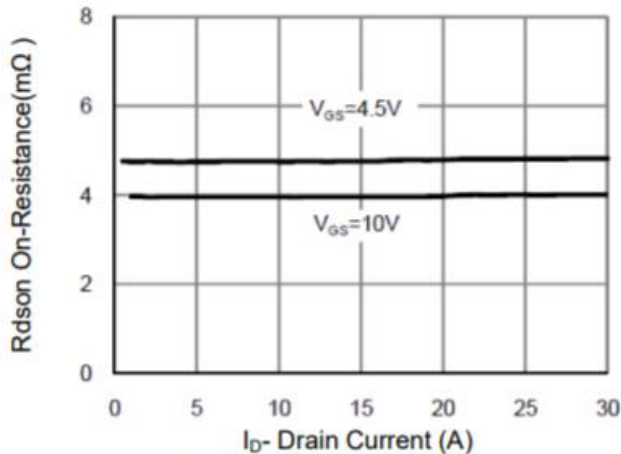

Figure 3 Rdson- Drain Current

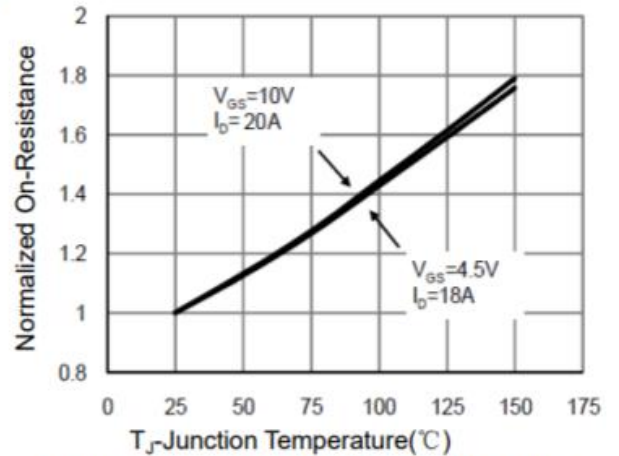

Figure 4 Rdson-Junction Temperature

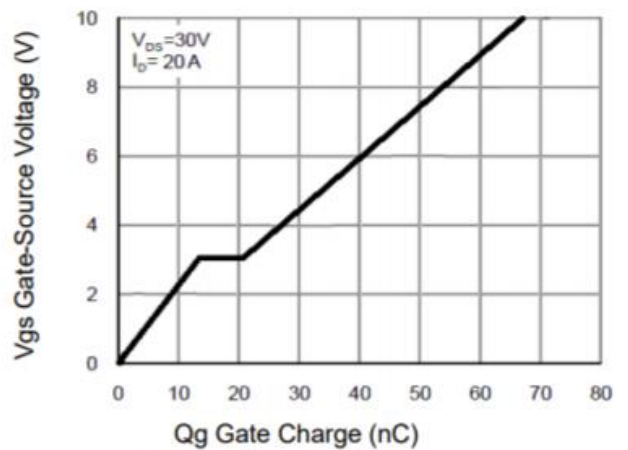

Figure 5 Gate Charge

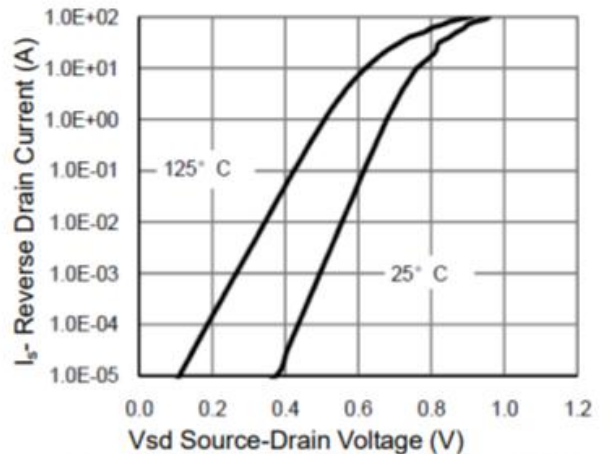

Figure 6 Source- Drain Diode Forward



GL80N06ADD

GL Silicon N-Channel Power MOSFET

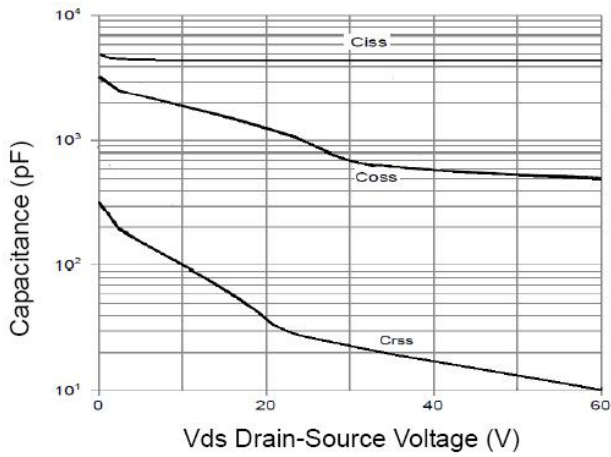

Figure 7 Capacitance vs Vds

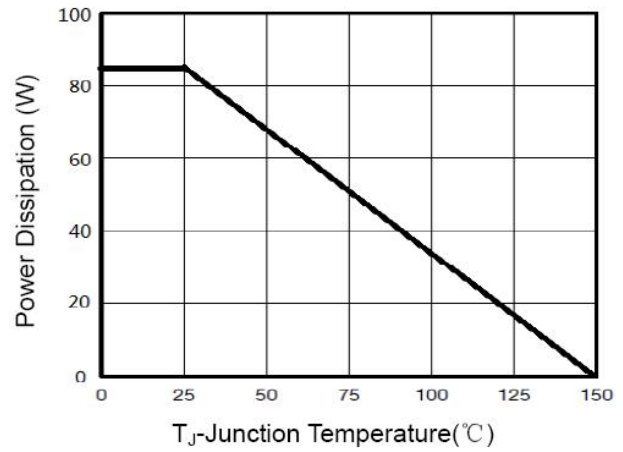

Figure 9 Power De-rating

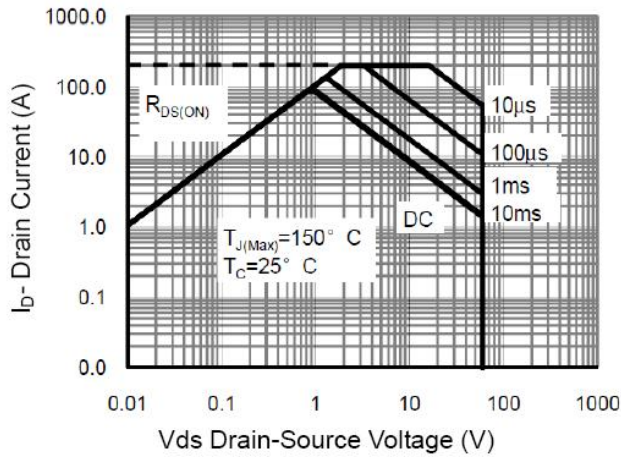

Figure 8 Safe Operation Area

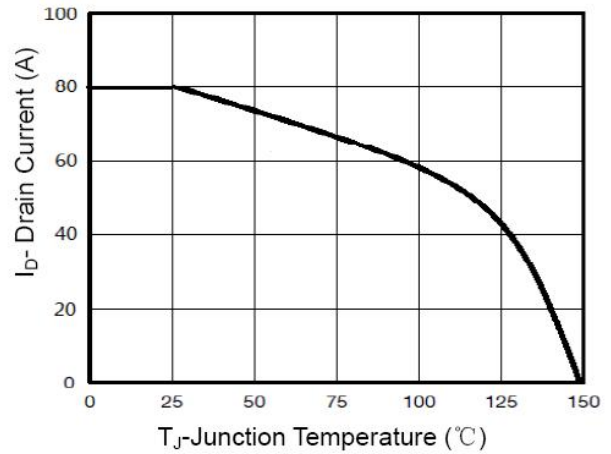

Figure 10 Current De-rating

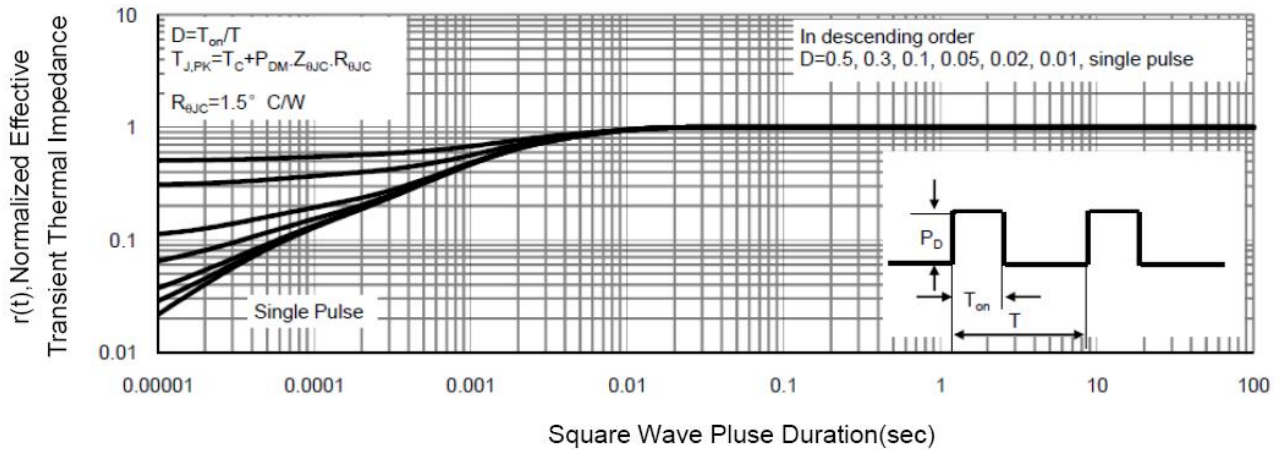

Figure 11 Normalized Maximum Transient Thermal Impedance