



# GL80N06A47H

## GL Silicon N-Channel Power MOSFET

### General Description

The GL80N06A47H uses advanced trench technology and design to provide excellent  $R_{DS(ON)}$  with low gate charge. It can be used in a wide variety of applications. The package form is TO-247, which accords with the RoHS standard.

$V_{DSS}$	60	V
$I_D$	80	A
$P_D$	180	W
$R_{DS(ON)type}$	6.5	m $\Omega$

### Features

- $R_{DS(ON)} < 8.0m\Omega @ V_{GS}=10V$  (Typ6.5m $\Omega$ )
- High density cell design for ultra low  $R_{dson}$
- Fully characterized avalanche voltage and current
- Excellent package for good heat dissipation

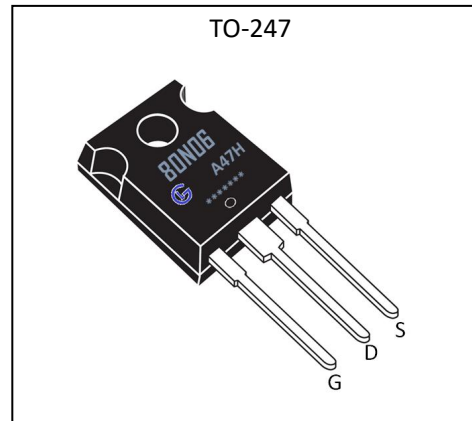

### Applications

- Power switching application
- Hard switched and high frequency circuits
- Uninterruptible power supply

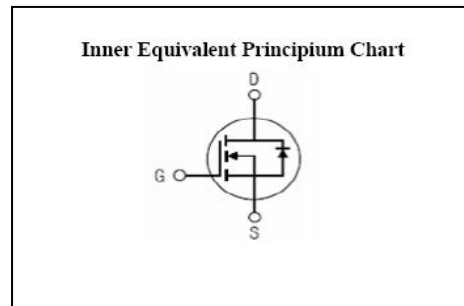

### Absolute (Tc= 25°C unless otherwise specified)

Symbol	Parameter	Rating	Units
$V_{DSS}$	Drain-to-Source Voltage	60	V
$I_D$	Continuous Drain Current	80	A
$I_{DM}$	Pulsed Drain Current	320	A
$V_{GS}$	Gate-to-Source Voltage	$\pm 20$	V
$P_D$	Power Dissipation	180	W
$E_{AS}$	Single pulse avalanche energy <sup>a5</sup>	390	mJ
$T_J, T_{stg}$	Operating Junction and Storage Temperature Range	175, -55 to 175	°C

Caution Stresses greater than those in the "Absolute Maximum Ratings" may cause permanent damage to the device

### Thermal Characteristics

Symbol	Parameter	Typ.	Units
$R_{\theta JC}$	Junction-to-Case <sup>a2</sup>	0.70	°C/W



# GL80N06A47H

## GL Silicon N-Channel Power MOSFET

### Electrical Characteristics (Tc= 25°C unless otherwise specified)

OFF Characteristics						
Symbol	Parameter	Test Conditions	Rating			Units
			Min.	Typ.	Max.	
V <sub>DSS</sub>	Drain to Source Breakdown Voltage	V <sub>GS</sub> =0V, I <sub>D</sub> =250μA	60	--	--	V
I <sub>DSS</sub>	Drain to Source Leakage Current	V <sub>DS</sub> =60V, V <sub>GS</sub> = 0V, T <sub>a</sub> =25°C	--	--	1.0	μA
I <sub>GSS(F)</sub>	Gate to Source Forward Leakage	V <sub>GS</sub> = +20V	--	--	0.1	μA
I <sub>GSS(R)</sub>	Gate to Source Reverse Leakage	V <sub>GS</sub> = -20V	--	--	-0.1	μA

ON Characteristics <sup>a3</sup>						
Symbol	Parameter	Test Conditions	Rating			Units
			Min.	Typ.	Max.	
R <sub>DS(ON)</sub>	Drain-to-Source On-Resistance	V <sub>GS</sub> =10V, I <sub>D</sub> =40A	--	6.5	8.0	mΩ
V <sub>GS(TH)</sub>	Gate Threshold Voltage	V <sub>DS</sub> =V <sub>GS</sub> , I <sub>D</sub> =250μA	2.0	--	4.0	V

Pulse width tp ≤ 380μs, δ ≤ 2%

Dynamic Characteristics <sup>a4</sup>						
Symbol	Parameter	Test Conditions	Rating			Units
			Min.	Typ.	Max.	
g <sub>fs</sub>	Forward Transconductance	V <sub>DS</sub> =10V, I <sub>D</sub> =20A	--	20	--	S
C <sub>iss</sub>	Input Capacitance	V <sub>GS</sub> =0V, V <sub>DS</sub> =30V f=1.0MHz	--	4000	--	pF
C <sub>oss</sub>	Output Capacitance		--	290	--	
C <sub>rss</sub>	Reverse Transfer Capacitance		--	210	--	

Resistive Switching Characteristics <sup>a4</sup>						
Symbol	Parameter	Test Conditions	Rating			Units
			Min.	Typ.	Max.	
t <sub>d(ON)</sub>	Turn-on Delay Time	V <sub>DD</sub> =30V, R <sub>L</sub> =1Ω V <sub>GS</sub> =10V, R <sub>G</sub> =3Ω	--	8.5	--	ns
t <sub>r</sub>	Rise Time		--	7	--	
t <sub>d(OFF)</sub>	Turn-Off Delay Time		--	40	--	
t <sub>f</sub>	Fall Time		--	15	--	
Q <sub>g</sub>	Total Gate Charge	V <sub>DD</sub> =30V, I <sub>D</sub> =20A V <sub>GS</sub> =10V	--	90	--	nC
Q <sub>gs</sub>	Gate to Source Charge		--	9	--	
Q <sub>gd</sub>	Gate to Drain ( "Miller" )Charge		--	18	--	



# GL80N06A47H

## GL Silicon N-Channel Power MOSFET

### Source-Drain Diode Characteristics

Symbol	Parameter	Test Conditions	Rating			Units
			Min.	Typ.	Max.	
$I_S$	Continuous Source Current <sup>a2</sup> (Body Diode)		--	--	80	A
$V_{SD}$	Diode Forward Voltage <sup>a3</sup>	$I_S=80A, V_{GS}=0V$	--	--	1.2	V

<sup>a1</sup>: Repetitive Rating: Pulse width limited by maximum junction temperature.

<sup>a2</sup>: Surface Mounted on FR4 Board,  $t \leq 10\text{sec}$ .

<sup>a3</sup>: Pulse Test: Pulse Width  $\leq 300\mu\text{s}$ , Duty Cycle  $\leq 2\%$ .

<sup>a4</sup>: Guaranteed by design, not subject to production

<sup>a5</sup>: EAS condition:  $T_j=25^\circ\text{C}, V_{DD}=20V, V_G=10V, L=0.5\text{mH}, R_g=25\Omega$

### Test Circuits

#### 1) EAS test Circuit

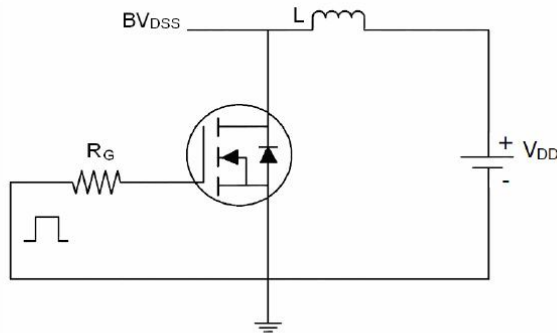

#### 2) Gate charge test Circuit

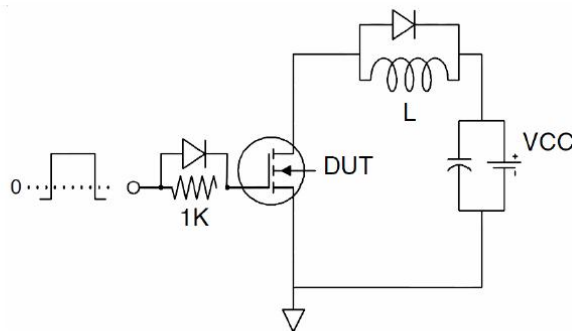

#### 3) Switch Time Test Circuit

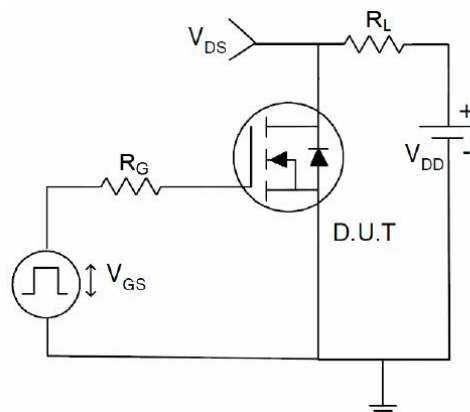



# GL80N06A47H

GL Silicon N-Channel Power MOSFET

## Characteristics Curves

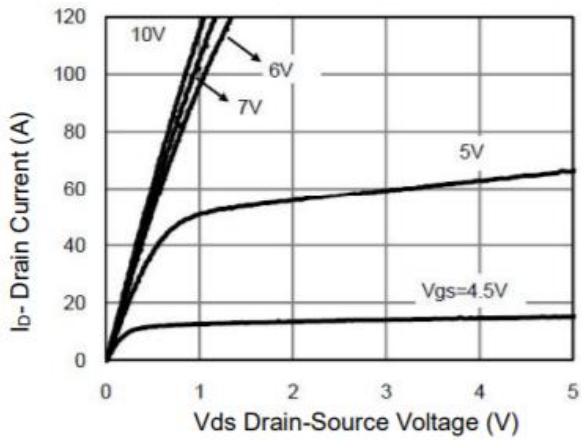

Figure 1 Output Characteristics

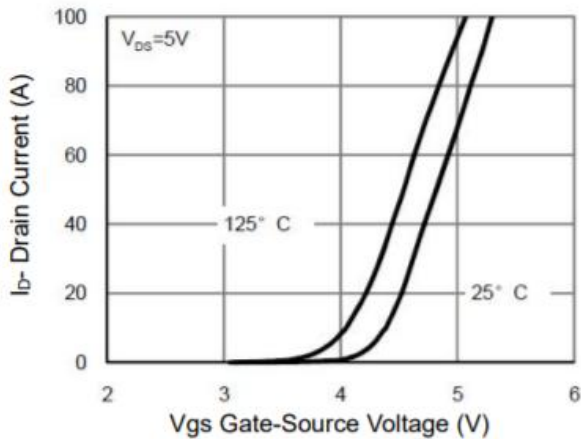

Figure 2 Transfer Characteristics

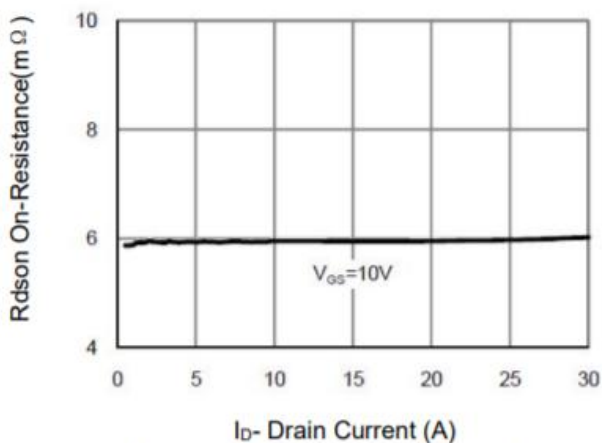

Figure 3 Rdson- Drain Current

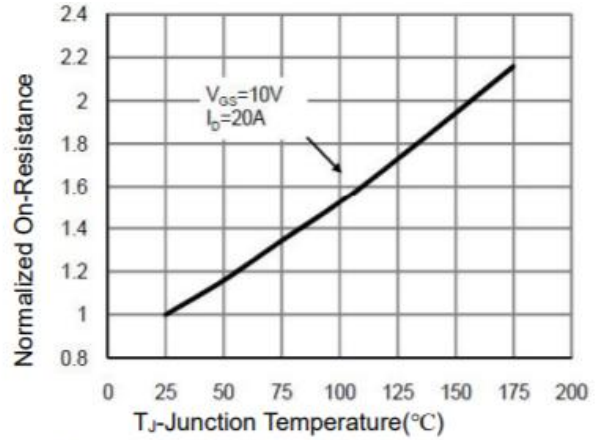

Figure 4 Rdson-Junction Temperature

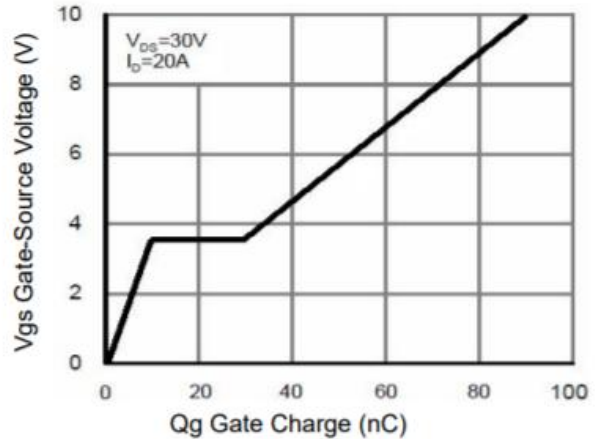

Figure 5 Gate Charge

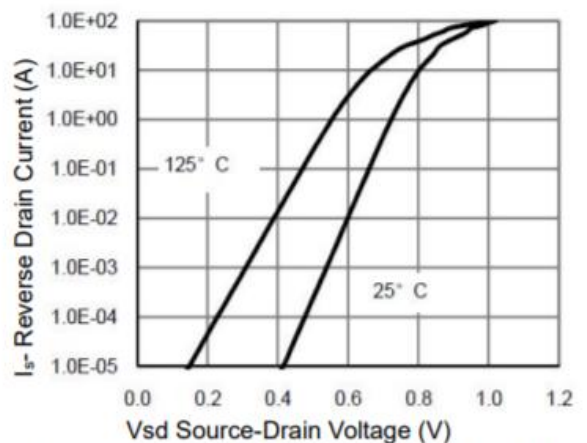

Figure 6 Source- Drain Diode Forward



# GL80N06A47H

## GL Silicon N-Channel Power MOSFET

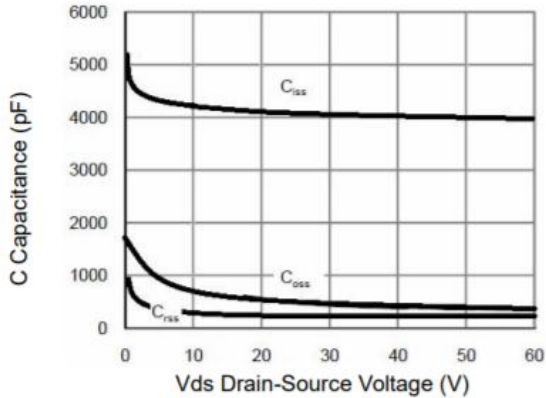

Figure 7 Capacitance vs Vds

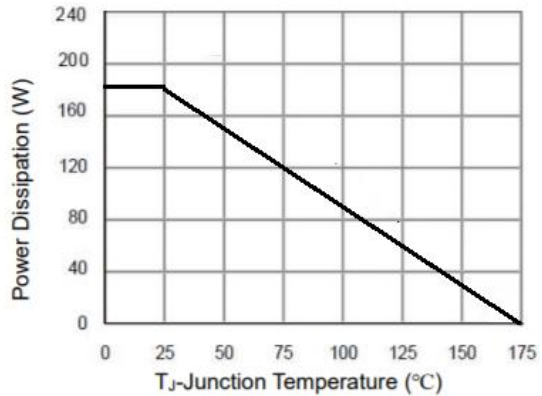

Figure 9 Power De-rating

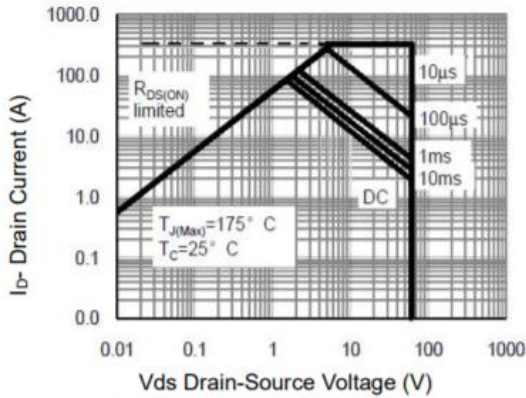

Figure 8 Safe Operation Area

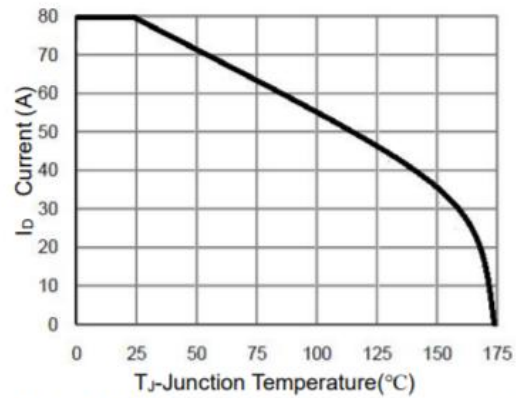

Figure 10 ID Current- Junction Temperature

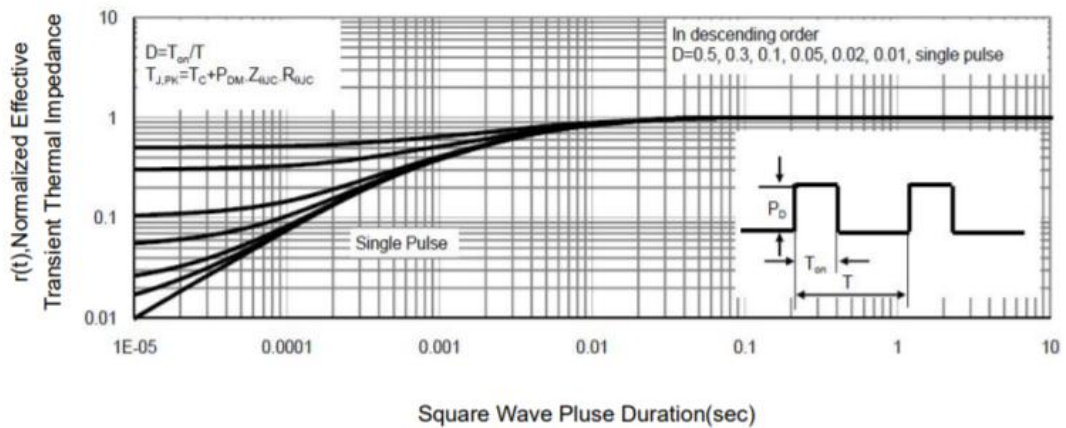

Figure 11 Normalized Maximum Transient Thermal Impedance