



GL5N20B4

GL Silicon N-Channel Power MOSFET

General Description:

GL5N20B4 the silicon N-channel Enhanced VDMOSFETS, is obtained by the self-aligned planar Technology which reduce the conduction loss, improve switching performance and enhance the avalanche energy. The transistor can be used in various power switching circuit for system miniaturization and higher efficiency. The package form is TO-252, which accords with the RoHS standard.

Features:

- Fast Switching
- Low Gate Charge
- Low Reverse transfer capacitances
- 100% Single Pulse avalanche energy Test

Applications:

- LED Lighting
- Charger
- Standby Power

Absolute (T_c=25°C unless otherwise specified):

Symbol	Parameter	Rating	Units
V _{DSS}	Drain-to-Source Voltage	200	V
I _D	Continuous Drain Current	5	A
	Continuous Drain Current T _c = 100 °C	3.5	A
I _{DM} ^{a1}	Pulsed Drain Current	20	A
V _{GS}	Gate-to-Source Voltage	± 20	V
E _{AS} ^{a2}	Single Pulse Avalanche Energy	30	mJ
dv/dt ^{a3}	Peak Diode Recovery dv/dt	5.0	V/ns
P _D	Power Dissipation	40	W
	Derating Factor above 25°C	0.6	W/°C
T _J , T _{stg}	Operating Junction and Storage Temperature Range	150, -55 to 150	°C
T _L	Maximum Temperature for Soldering	300	°C

V _{DSS}	200	V
I _D	5	A
P _D (T _c =25°C)	40	W
R _{DS(ON)typ}	2.5	Ω

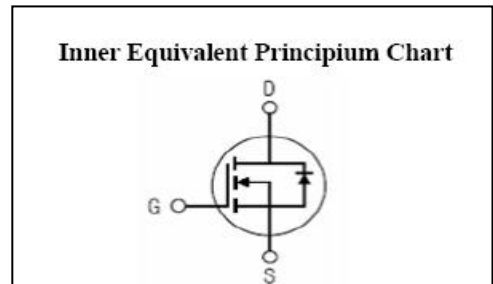
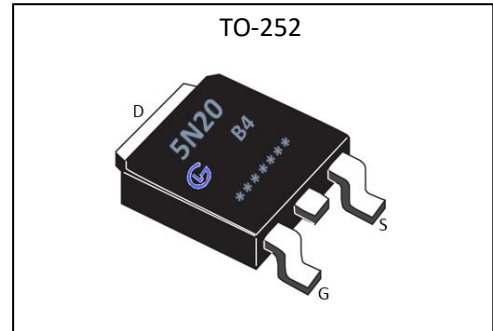



GL5N20B4

GL Silicon N-Channel Power MOSFET

Electrical Characteristics ($T_c=25^\circ\text{C}$ unless otherwise specified) :

OFF Characteristics						
Symbol	Parameter	Test Conditions	Rating			Units
			Min.	Typ.	Max.	
V_{DSS}	Drain to Source Breakdown Voltage	$V_{GS}=0V, I_D=250\mu A$	200	--	--	V
$\Delta BV_{DSS}/\Delta T_j$	Bvdss Temperature Coefficient	$I_D=250\mu A, \text{Reference } 25^\circ\text{C}$	--	0.21	--	V/ $^\circ\text{C}$
I_{DSS}	Drain to Source Leakage Current	$V_{DS}=200V, V_{GS}=0V, T_a=25^\circ\text{C}$	--	--	1	μA
		$V_{DS}=160V, V_{GS}=0V, T_a=125^\circ\text{C}$	--	--	100	
$I_{GSS(F)}$	Gate to Source Forward Leakage	$V_{GS}=+30V$	--	--	100	nA
$I_{GSS(R)}$	Gate to Source Reverse Leakage	$V_{GS}=-30V$	--	--	-100	nA

ON Characteristics						
Symbol	Parameter	Test Conditions	Rating			Units
			Min.	Typ.	Max.	
$R_{DS(ON)}$	Drain-to-Source On-Resistance	$V_{GS}=4.5V, I_D=0.5A$	--	2.5	3.0	Ω
$R_{DS(ON)}$	Drain-to-Source On-Resistance	$V_{GS}=2.5V, I_D=0.5A$	--	2.8	4.0	Ω
$V_{GS(TH)}$	Gate Threshold Voltage	$V_{DS}=V_{GS}, I_D=250\mu A$	0.4	0.7	1.5	V

Pulse width $t_p \leq 300\mu s, \delta \leq 2\%$

Dynamic Characteristics						
Symbol	Parameter	Test Conditions	Rating			Units
			Min.	Typ.	Max.	
g_{fs}	Forward Transconductance	$V_{DS}=25V, I_D=2.5A$	--	1.0	--	S
C_{iss}	Input Capacitance	$V_{GS}=0V, V_{DS}=25V$ $f=1.0\text{MHz}$	--	80	--	pF
C_{oss}	Output Capacitance		--	6	--	
C_{rss}	Reverse Transfer Capacitance		--	2	--	

Resistive Switching Characteristics						
Symbol	Parameter	Test Conditions	Rating			Units
			Min.	Typ.	Max.	
$t_{d(ON)}$	Turn-on Delay Time	$I_D=5A, V_{DD}=100V$ $R_G=10\Omega$	--	2	--	ns
t_r	Rise Time		--	4	--	
$t_{d(OFF)}$	Turn-Off Delay Time		--	6	--	
t_f	Fall Time		--	3	--	
Q_g	Total Gate Charge	$I_D=5A, V_{DD}=100V$ $V_{GS}=10V$	--	2	--	nC
Q_{gs}	Gate to Source Charge		--	1	--	
Q_{gd}	Gate to Drain ("Miller") Charge		--	1.2	--	



GL5N20B4

GL Silicon N-Channel Power MOSFET

Source-Drain Diode Characteristics

Symbol	Parameter	Test Conditions	Rating			Units
			Min.	Typ.	Max.	
I_S	Continuous Source Current (Body Diode)		--	--	5	A
I_{SM}	Maximum Pulsed Current (Body Diode)		--	--	40	A
V_{SD}	Diode Forward Voltage	$I_S=5.0A, V_{GS}=0V$	--	--	1.5	V
t_{rr}	Reverse Recovery Time	$I_S=5.0A, T_J=25^\circ C$	--	50	--	ns
Q_{rr}	Reverse Recovery Charge	$di_F/dt=100A/us,$	--	40	--	μC
I_{RRM}	Reverse Recovery Current	$V_{GS}=0V$	--	1	--	A

Pulse width $t_p \leq 300\mu s, \delta \leq 2\%$

Symbol	Parameter	Typ.	Units
$R_{\theta JC}$	Junction-to-Case	3.13	$^\circ C/W$
$R_{\theta JA}$	Junction-to-Ambient	62.5	$^\circ C/W$

^{a1}: Repetitive rating; pulse width limited by maximum junction temperature

^{a2}: $L=10.0mH, I_D=1A, Start T_J=25^\circ C$

^{a3}: $I_{SD}=5A, di/dt \leq 100A/us, V_{DD} \leq BV_{DS}, Start T_J=25^\circ C$



GL5N20B4

GL Silicon N-Channel Power MOSFET

Characteristics Curve:

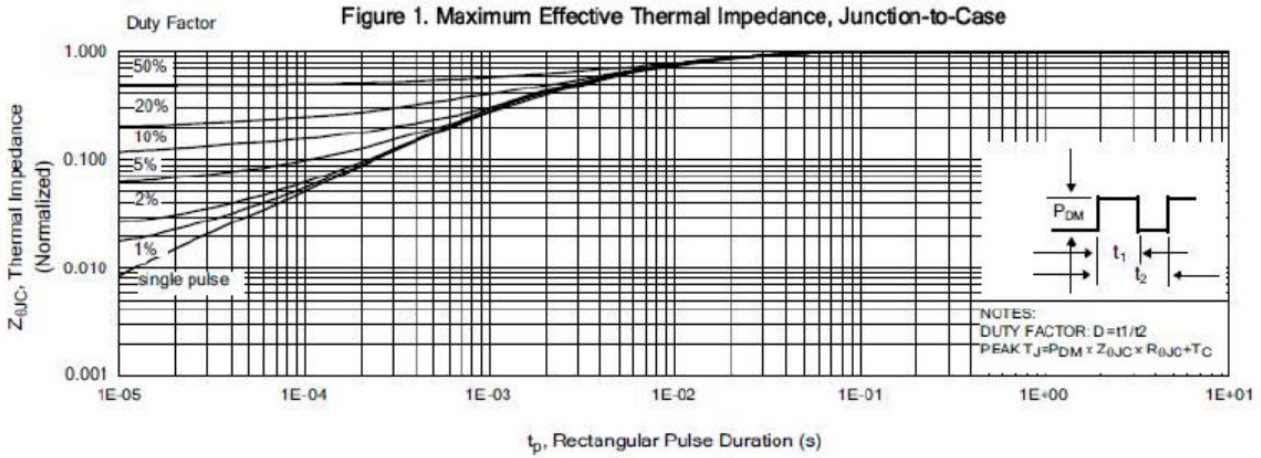

Figure 2. Maximum Power Dissipation vs Case Temperature

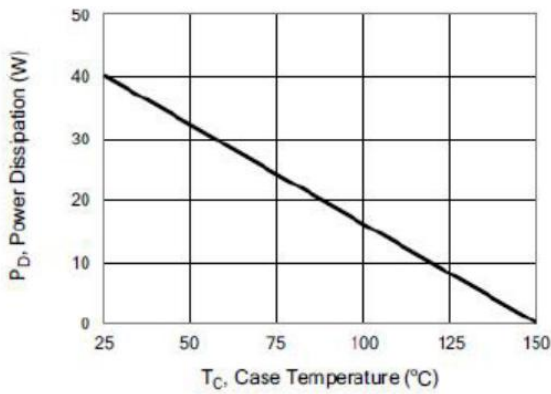

Figure 3. Maximum Continuous Drain Current vs Case Temperature

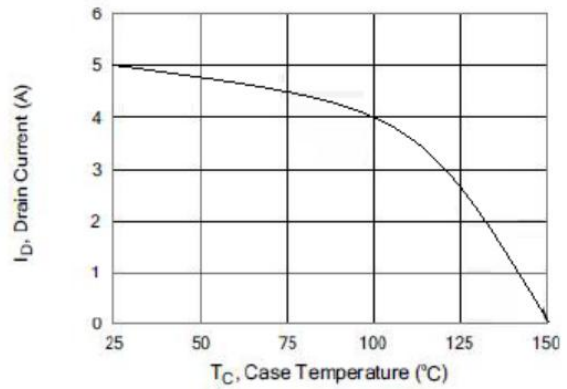

Figure 4. Typical Output Characteristics

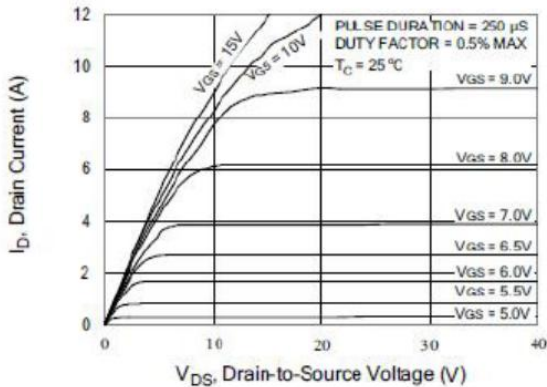
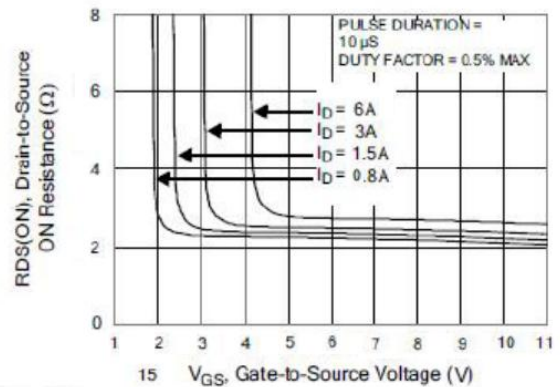

Figure 5. Typical Drain-to-Source ON Resistance vs Gate Voltage and Drain Current





GL5N20B4

GL Silicon N-Channel Power MOSFET

Figure 6. Maximum Peak Current Capability

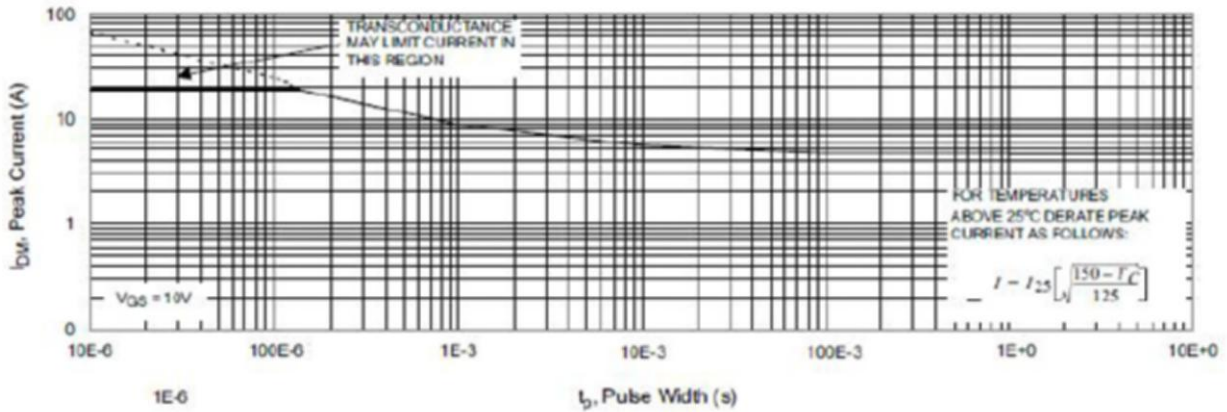

Figure 7. Typical Transfer Characteristics

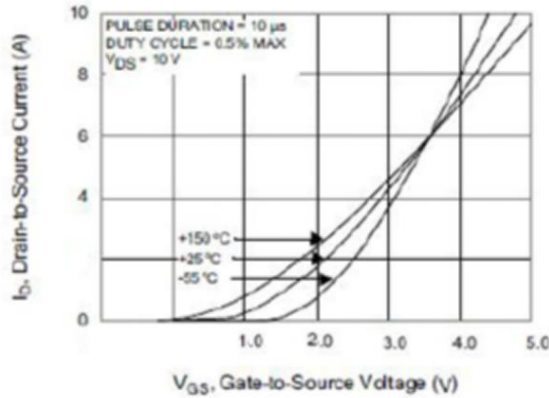

Figure 8. Unclamped Inductive Switching Capability

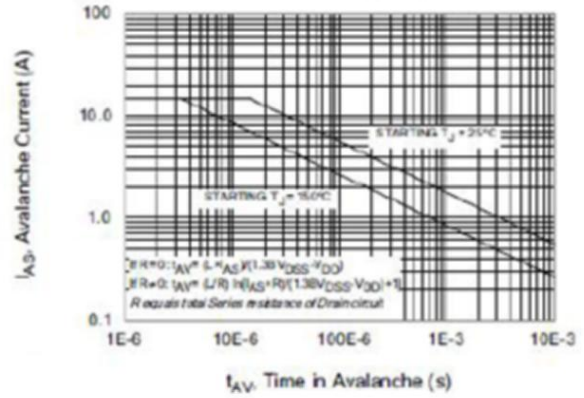

Figure 9. Typical Drain-to-Source ON Resistance vs Drain Current

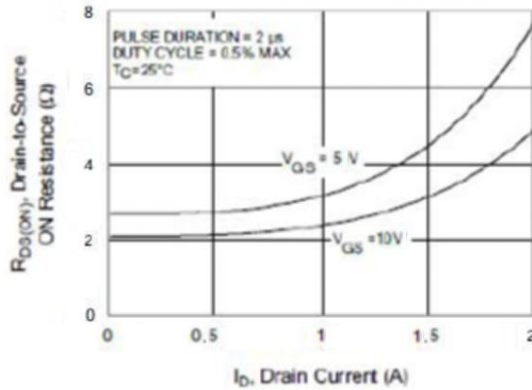
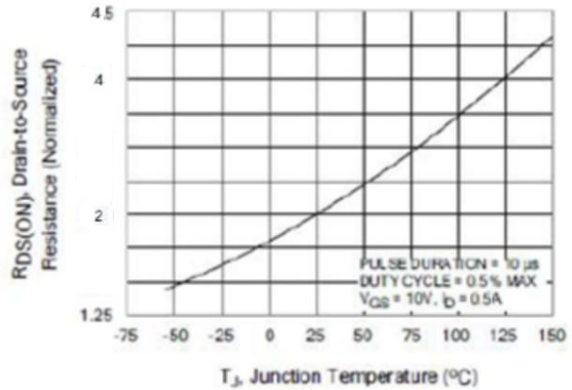

Figure 10. Typical Drain-to-Source ON Resistance vs Junction Temperature





GL5N20B4

GL Silicon N-Channel Power MOSFET

Figure 11. Typical Breakdown Voltage vs Junction Temperature

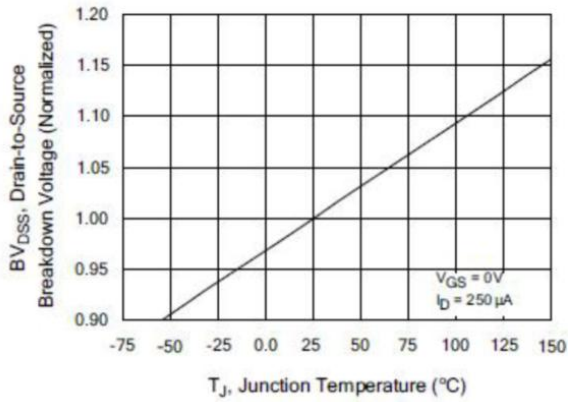

Figure 12. Typical Threshold Voltage vs Junction Temperature

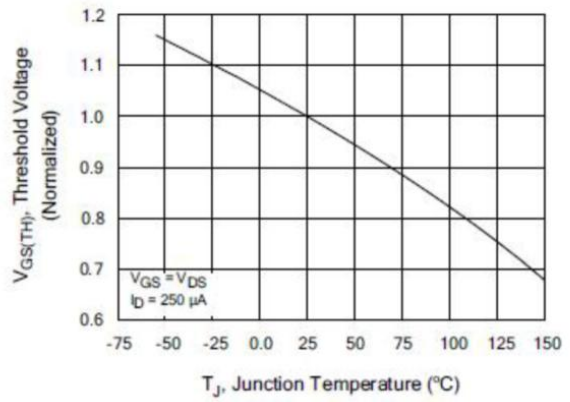

Figure 13. Maximum Forward Bias Safe Operating Area

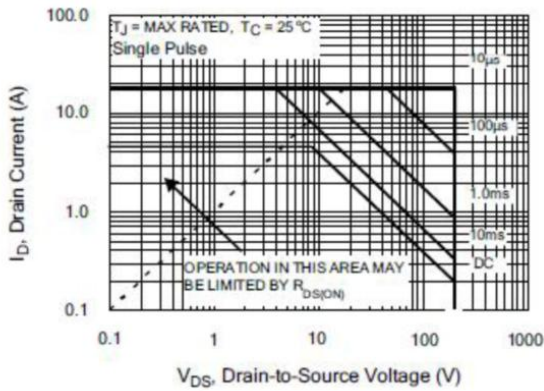

Figure 14. Typical Capacitance vs Drain-to-Source Voltage

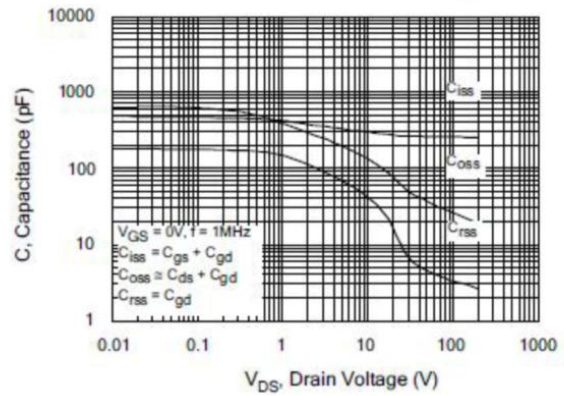

Figure 15. Typical Gate Charge vs Gate-to-Source Voltage

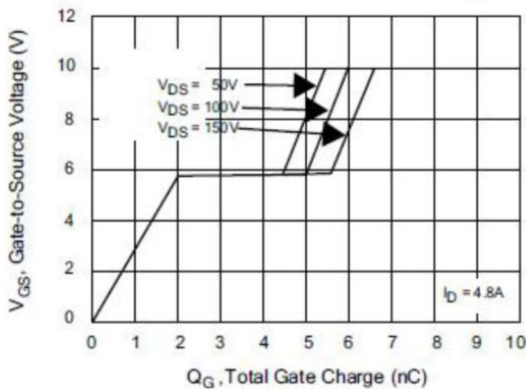

Figure 16. Typical Body Diode Transfer Characteristics

