



GL7N90FA9

GL Silicon N-Channel Power MOSFET

General Description

GL7N90FA9 the silicon N-channel Enhanced VDMOSFETS, is obtained by the self-aligned planar Technology which reduce the conduction loss, improve switching performance and enhance the avalanche energy. The transistor can be used in various power switching circuit for system miniaturization and higher efficiency. The package form is TO-220F, which accords with the RoHS standard.

V_{DSS}	900	V
I_D	7	A
$P_D (T_C=25^{\circ}C)$	45	W
$R_{DS(ON)TYP}$	1.4	Ω

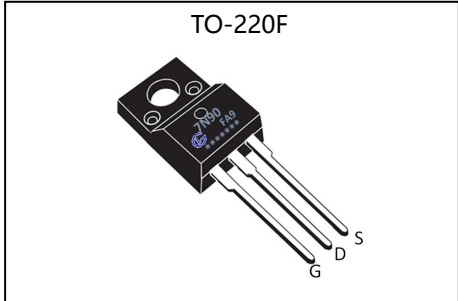

Features

- Fast Switching
- Low Gate Charge and R_{dson}
- Low Reverse transfer capacitances
- 100% Single Pulse avalanche energy Test

Applications

- Power switch circuit of adaptor and charger

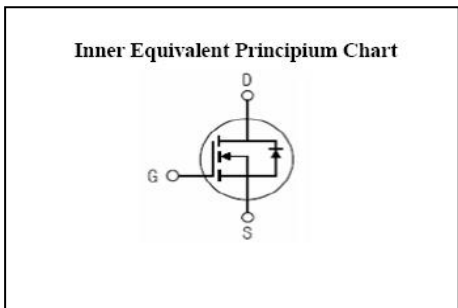

Absolute (Tc= 25°C unless otherwise specified)

Symbol	Parameter	Rating	Units
V_{DSS}	Drain-to-Source Voltage	900	V
I_D	Continuous Drain Current	7.0	A
	Continuous Drain Current $T_C = 100^{\circ}C$	5.0	A
I_{DM}^{a1}	Pulsed Drain Current	28	A
V_{GS}	Gate-to-Source Voltage	± 30	V
E_{AS}^{a2}	Single Pulse Avalanche Energy	700	mJ
E_{AR}^{a1}	Avalanche Energy ,Repetitive	60	mJ
I_{AR}^{a1}	Avalanche Current	2.4	A
dv/dt^{a3}	Peak Diode Recovery dv/dt	5.0	V/ns
P_D	Power Dissipation	45	W
	Derating Factor above 25°C	0.36	W/°C
T_J, T_{stg}	Operating Junction and Storage Temperature Range	150, -55 to 150	°C
T_L	Maximum Temperature for Soldering	300	°C

Caution Stresses greater than those in the "Absolute Maximum Ratings" may cause permanent damage to the device

Thermal Characteristics

Symbol	Parameter	Typ.	Units
$R_{\theta JC}$	Junction-to-Case	2.78	°C/W
$R_{\theta JA}$	Junction-to-Ambient	100	°C/W



GL7N90FA9

GL Silicon N-Channel Power MOSFET

Electrical Characteristics ($T_c = 25^\circ\text{C}$ unless otherwise specified)

OFF Characteristics						
Symbol	Parameter	Test Conditions	Rating			Units
			Min.	Typ.	Max.	
V_{DSS}	Drain to Source Breakdown Voltage	$V_{GS}=0V, I_D=250\mu A$	900	--	--	V
$\Delta BV_{DSS}/\Delta T_J$	BV_{DSS} Temperature Coefficient	$I_D=250\mu A, \text{Reference } 25^\circ\text{C}$	--	0.8	--	V/ $^\circ\text{C}$
I_{DSS}	Drain to Source Leakage Current	$V_{DS}=900V, V_{GS}=0V, T_a=25^\circ\text{C}$	--	--	1	μA
		$V_{DS}=720V, V_{GS}=0V, T_a=125^\circ\text{C}$	--	--	250	
$I_{GSS(F)}$	Gate to Source Forward Leakage	$V_{GS} = +30V$	--	--	10	μA
$I_{GSS(R)}$	Gate to Source Reverse Leakage	$V_{GS} = -30V$	--	--	-10	μA

ON Characteristics						
Symbol	Parameter	Test Conditions	Rating			Units
			Min.	Typ.	Max.	
$R_{DS(ON)}$	Drain-to-Source On-Resistance	$V_{GS}=10V, I_D=3.0A$	--	1.4	1.6	Ω
$V_{GS(TH)}$	Gate Threshold Voltage	$V_{DS}=V_{GS}, I_D=250\mu A$	2.5	--	4.5	V
Pulse width $t_p \leq 380\mu s, \delta \leq 2\%$						

Dynamic Characteristics						
Symbol	Parameter	Test Conditions	Rating			Units
			Min.	Typ.	Max.	
g_{fs}	Forward Trans conductance	$V_{DS}=15V, I_D=3A$	--	8.0	--	S
C_{iss}	Input Capacitance	$V_{GS}=0V, V_{DS}=25V$ $f=1.0\text{MHz}$	--	1460	--	μF
C_{oss}	Output Capacitance		--	130	--	
C_{rss}	Reverse Transfer Capacitance		--	23	--	

Resistive Switching Characteristics						
Symbol	Parameter	Test Conditions	Rating			Units
			Min.	Typ.	Max.	
$t_{d(ON)}$	Turn-on Delay Time	$I_D=7.0A, V_{DD}=450V$ $V_{GS}=10V, R_G=9.1\Omega$	--	22	--	ns
t_r	Rise Time		--	45	--	
$t_{d(OFF)}$	Turn-Off Delay Time		--	33	--	
t_f	Fall Time		--	37	--	
Q_g	Total Gate Charge	$I_D=7.0A, V_{DD}=450V$ $V_{GS}=10V$	--	37	--	nC
Q_{gs}	Gate to Source Charge		--	8.0	--	
Q_{gd}	Gate to Drain ("Miller") Charge		--	14	--	

Source-Drain Diode Characteristics

Symbol	Parameter	Test Conditions	Rating			Units
			Min.	Typ.	Max.	
I_S	Continuous Source Current (Body Diode)		--	--	7	A
I_{SM}	Maximum Pulsed Current (Body Diode)		--	--	28	A
V_{SD}	Diode Forward Voltage	$I_S = 7.0A, V_{GS} = 0V$	--	--	1.5	V
t_{rr}	Reverse Recovery Time	$I_S = 7.0A, T_j = 25^\circ C$	--	380	--	ns
Q_{rr}	Reverse Recovery Charge	$di_F/dt = 100A/\mu s, V_{GS} = 0V$	--	1400	--	nC

Pulse width $t_p \leq 380\mu s, \delta \leq 2\%$

^{a1}: Repetitive rating; pulse width limited by maximum junction temperature

^{a2}: $L = 10.0mH, I_D = 11.8A, \text{Start } T_j = 25^\circ C$

^{a3}: $I_{SD} = 7A, di/dt \leq 100A/\mu s, V_{DD} \leq BV_{DS}, \text{Start } T_j = 25^\circ C$

Test Circuit and Waveform

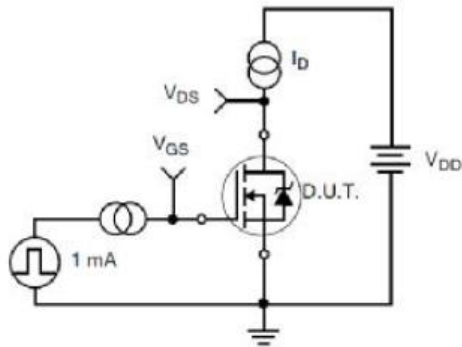

Figure 17. Gate Charge Test Circuit

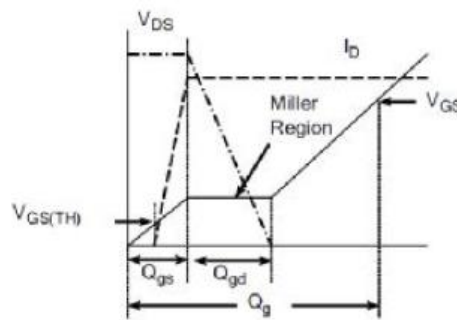

Figure 18. Gate Charge Waveform

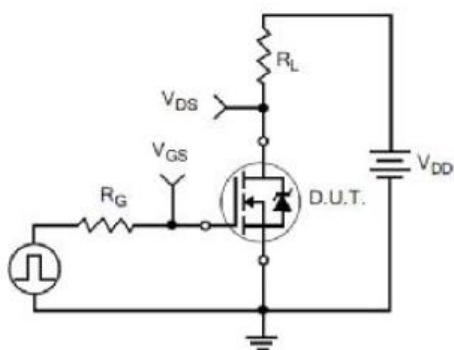

Figure 19. Resistive Switching Test Circuit

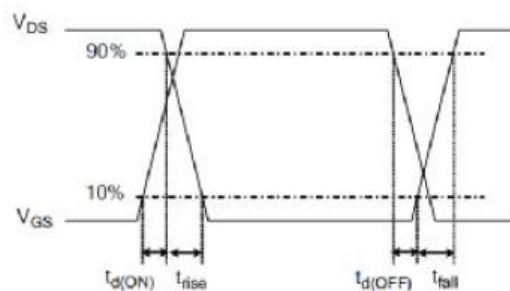

Figure 20. Resistive Switching Waveforms



GL7N90FA9

GL Silicon N-Channel Power MOSFET

Characteristics Curves

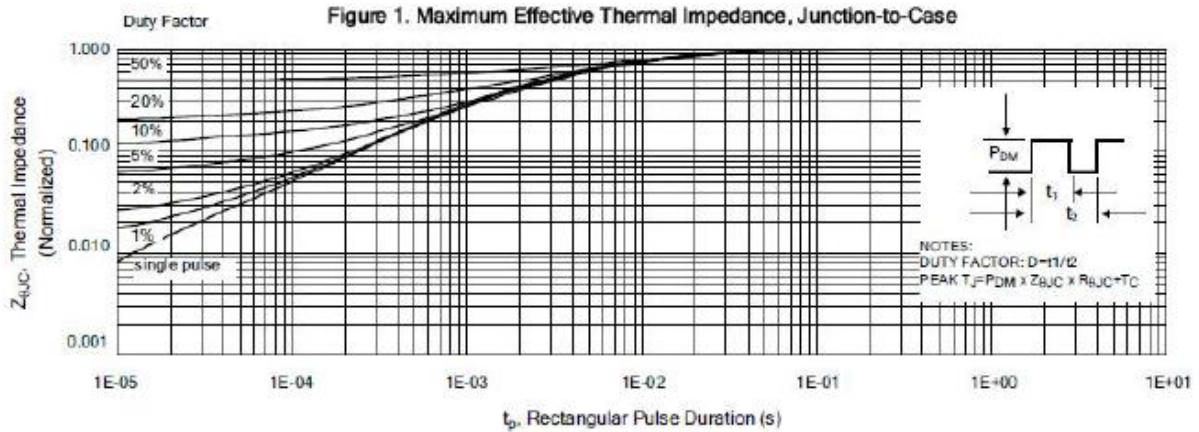

Figure 2. Maximum Power Dissipation vs Case Temperature

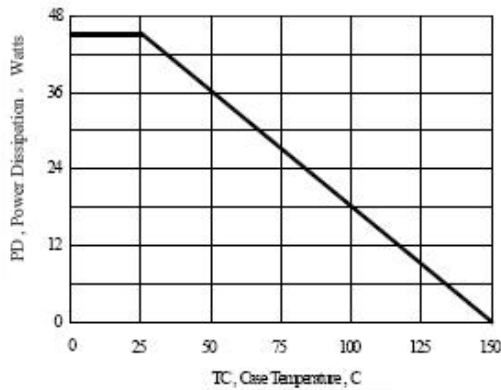

Figure 3. Maximum Continuous Drain Current vs Case Temperature

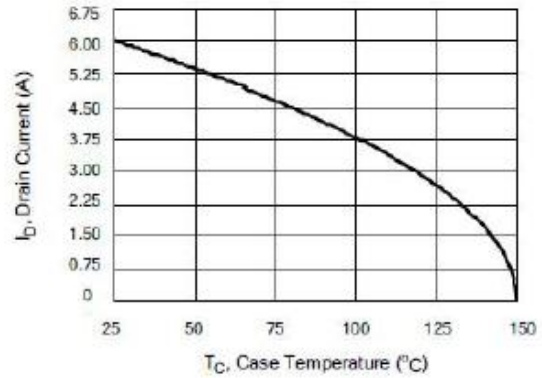

Figure 4. Typical Output Characteristics

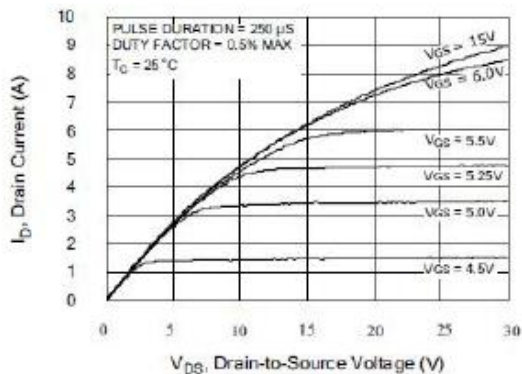
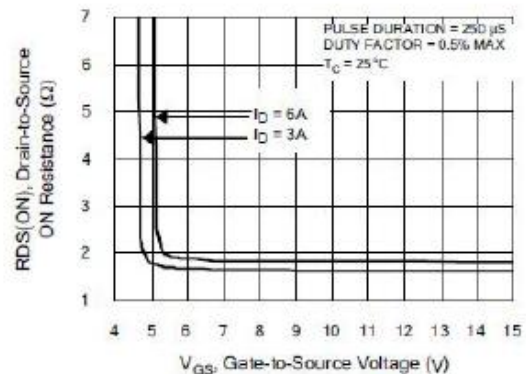

Figure 5. Typical Drain-to-Source ON Resistance vs Gate Voltage and Drain Current





GL7N90FA9

GL Silicon N-Channel Power MOSFET

Figure 6. Maximum Peak Current Capability

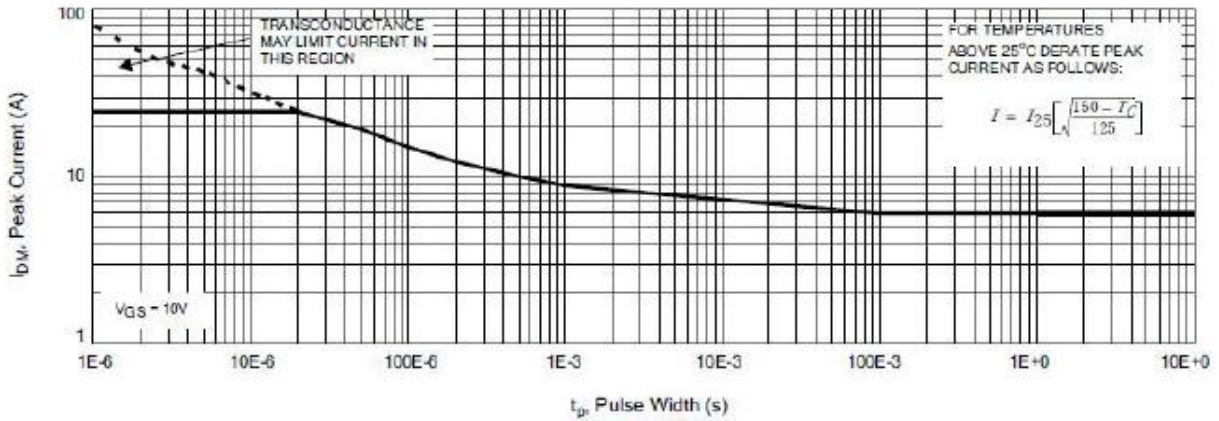

Figure 7. Typical Transfer Characteristics

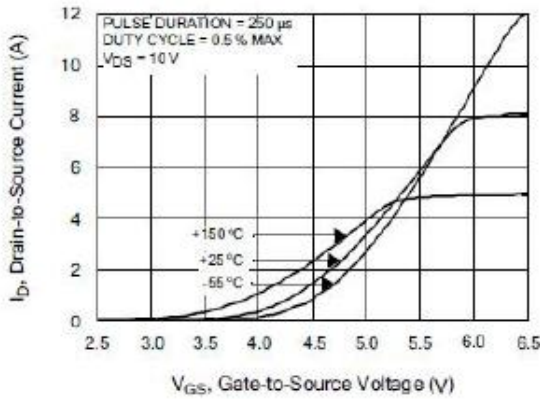

Figure 8. Unclamped Inductive Switching Capability

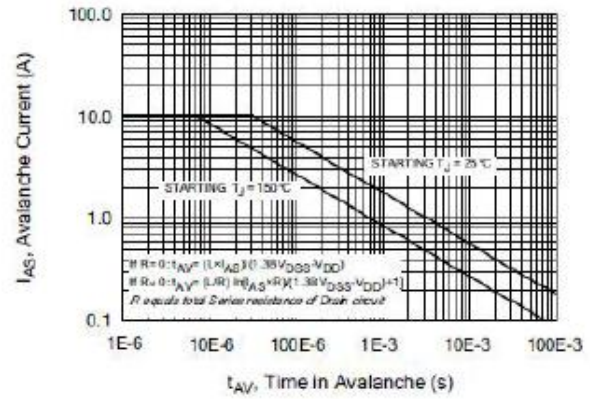

Figure 9. Typical Drain-to-Source ON Resistance vs Drain Current

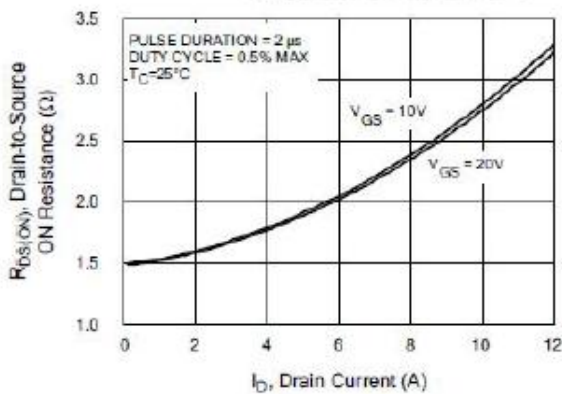
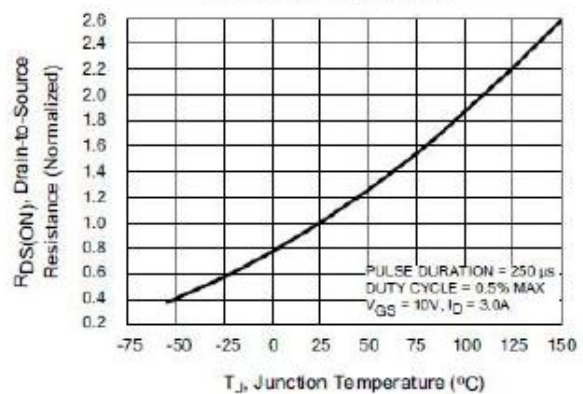

Figure 10. Typical Drain-to-Source ON Resistance vs Junction Temperature





GL7N90FA9

GL Silicon N-Channel Power MOSFET

Figure 11. Typical Breakdown Voltage vs Junction Temperature

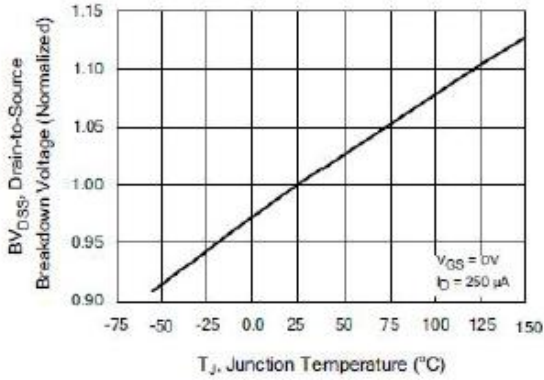

Figure 12. Typical Threshold Voltage vs Junction Temperature

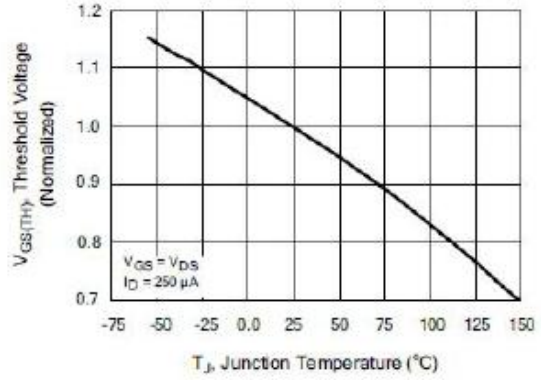

Figure 13. Maximum Forward Bias Safe Operating Area

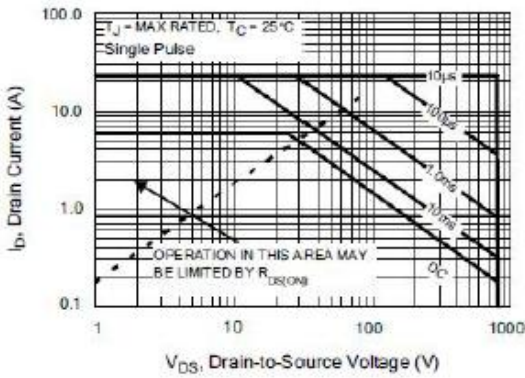

Figure 14. Typical Capacitance vs

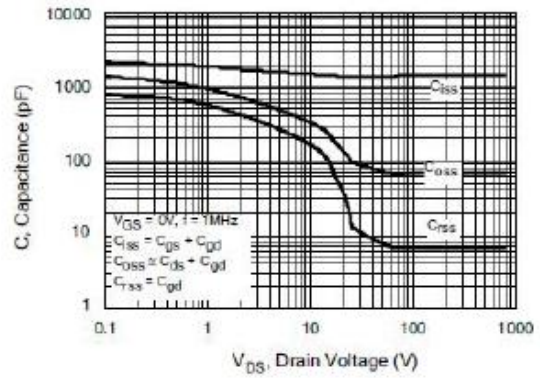

Figure 15. Typical Gate Charge vs Gate-to-Source Voltage

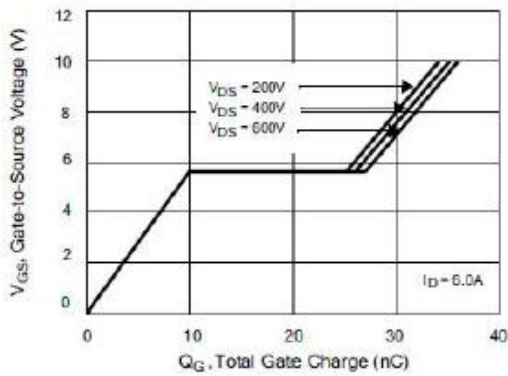
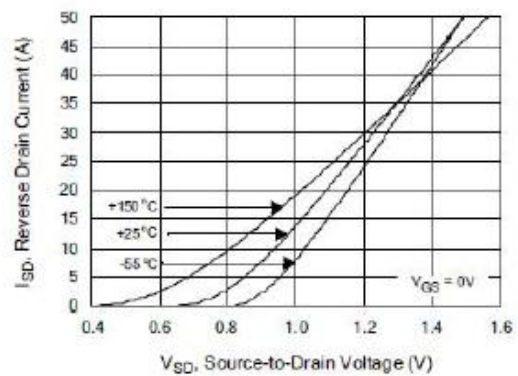

Figure 16. Typical Body Diode Transfer Characteristics





GL7N90FA9

GL Silicon N-Channel Power MOSFET

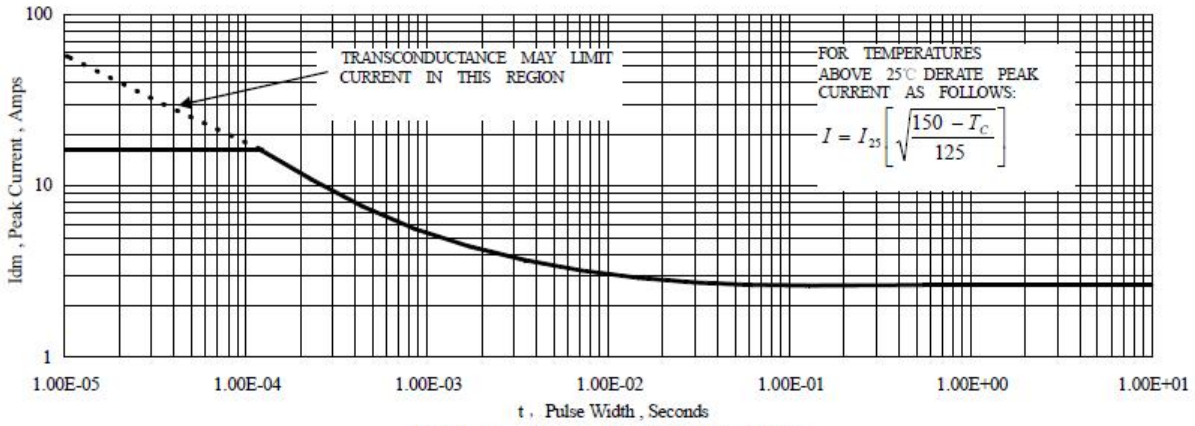

Figure 6 Maximum Peak Current Capability

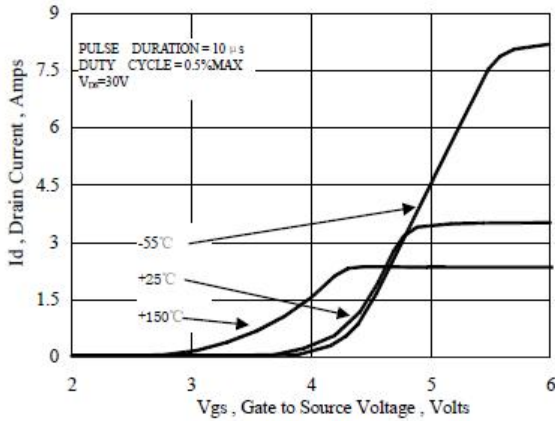

Figure 7 Typical Transfer Characteristics

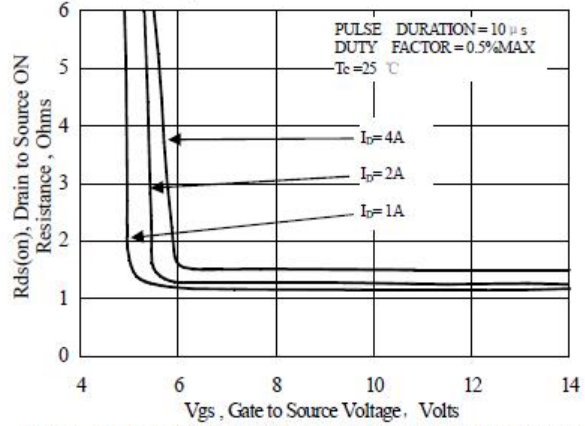

Figure 8 Typical Drain to Source ON Resistance vs Gate Voltage and Drain Current

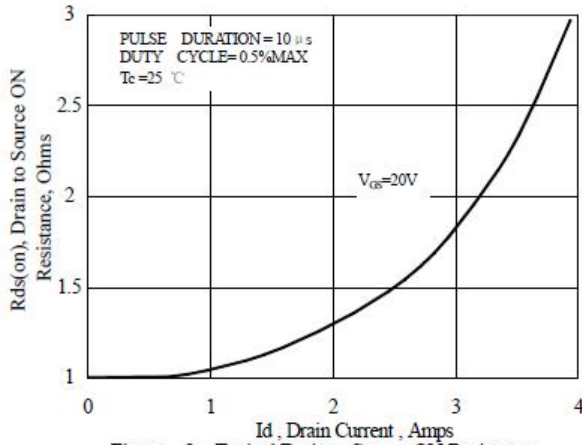

Figure 9 Typical Drain to Source ON Resistance vs Drain Current

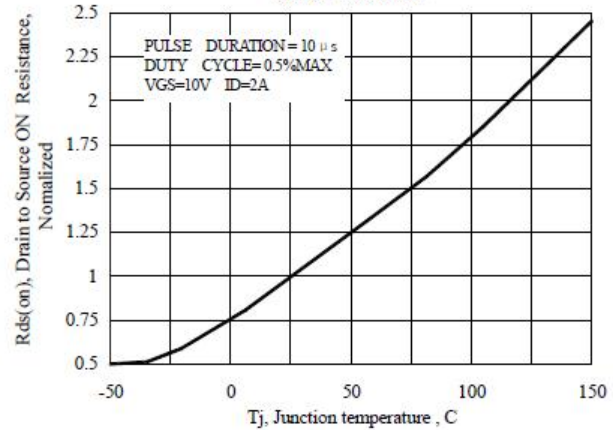

Figure 10 Typical Drain to Source on Resistance vs Junction Temperature